

Mathematical Modelling of Solar Systems

Alma Kujović *, Saša Mujović **

Keywords: photoelectric effect, mathematical modelling of elements, solar power plant.

Abstract: The photoelectric effect is the emission of electrons from metals under the action of light. In 1921, Einstein won the Nobel Prize for explaining the photoelectric effect, which says that light has the nature of particulate or light extends in quanta called photons. The photovoltaic effect and photoelectric effect are not the same concept. These are two directly related terms but the difference is that the photoelectric effect releases electrons from the surface of the material, after exposure to a sufficient amount of energy from sunlight. The photovoltaic effect releases electrons to pass between molecules of different material compounds, which causes an increase in voltage between the two electrodes. This discovery is the basis for the development of electricity generation from solar energy. Further development and achievement are given further in the work.

1. INTRODUCTION

A photovoltaic cell is a semiconductor element that converts solar energy into electrical energy using the photoelectric effect - the creation of voltage (current) in materials under the action of light.

Solar cells convert the energy of the Sun directly into direct current. Photovoltaic modules are connected to the power distribution network, so the integral part of solar systems is an inverter for converting direct current (DC) to alternating current (AC). The common term PV cells is a p-n junction that allows a photovoltaic effect. Light has a dual character, it is both a particle and a wave. Photons are particles of light, they are moving at the speed of light and they are massless. The energy of photons depends on frequency, as Einstein explained in the quantum energy theory of a single photon:

$$E = h \cdot f = h \cdot \frac{c}{\lambda} = \frac{1.239}{\lambda} \text{ [eV]} \quad (1.1)$$

$h = 6.624 \cdot 10^{-34}$ Js - Planck constant,

f [Hz] - photon frequency,

$c = 3 \cdot 10^8$ [m/s] - the speed of light,

*Alma Kujović (corresponding author) is with the Faculty of Electrical Engineering, University of Montenegro, Montenegro (phone: 382-68-856681; e mail: alma902009@hotmail.com)

*Dr Saša Mujović is with the Faculty of Electrical Engineering, University of Montenegro, Montenegro, (e mail: sasam@ucg.ac.me)

λ [μm] - the wavelength of radiation.

Electrons can be valence or free. Valence electrons are bound to an atom, and free electrons can move freely. The path of electrons from valence to free is caused by the electron obtaining energy that is greater than or equal to the binding energy. The energy with which an electron is bound to an atom in one of the atomic bonds is precisely this bonding energy. With the presence of solar energy, there is a collision between the photon and the semiconductor element, which receives the necessary energy and creates a photoelectric effect. The electron is released from the atom to which it is bound by obtaining part of the photon energy, while the remaining part of the energy is converted into kinetic energy. Free electrons obtained by the photoelectric effect are called photoelectrons.

$$E = h \cdot f = W_i + E_{\text{kin}} \tag{1.2}$$

$h \cdot f$ - photon energy,

W_i - output operation,

E_{kin} - kinetic energy of the emitted electron.

$n \cdot p = n^2$ the amount of doped electrification in a semiconductor is proportional to the square of its amount of electrification of that semiconductor.

PN CONNECTION

The PN junction is formed by connecting two semiconductor circuit boards, one P-type and the other N-type. [1]

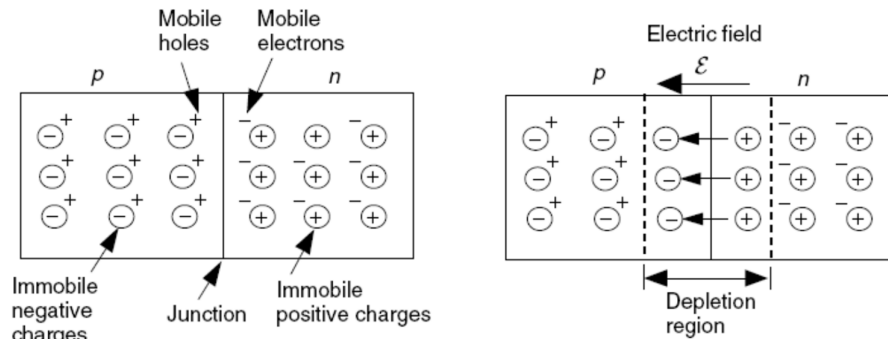

Fig. 1. PN junction formation process

Due to the difference in the concentration of electrocution in the junction, there is a movement of holes from the P area to the N area- from the area where their concentration is large in the area of lower concentration. This motion of electrification is a diffuse current. The electrons will also move diffusely from the N area to the P. The PN connection can be polarized directly ("+" pole of the battery attached to P, and "-" pole to N) and inverse ("+" pole of the battery attached to N, and "-" pole to P), depending on the voltage supplied, how we connect it to the PN-junction. In a directly polarized PN-junction, the potential barrier is reduced to allow the movement of electrons from the N region to the P region, and the holes

from the P to the N region. With a higher voltage, the current is also higher. With an inversely polarized PN junction, we have the opposite situation. The inversely polarized compound does not allow the flow of diffuse current. Through the PN-junction flows only the inverse current of saturation, which consists of secondary charge carriers. The value of current and voltage are not dependent, at the moment when the voltage reaches the value of the breakthrough voltage, the current begins to rise sharply. [1]

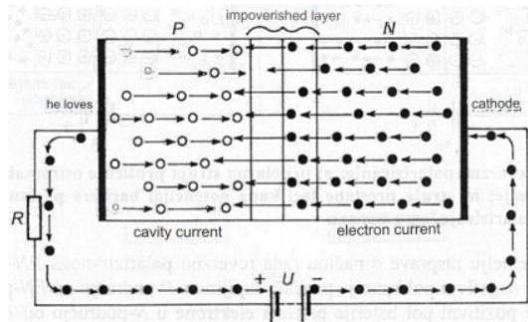

Fig. 2. Rectifier diodes consist of p-type and n-type semiconductors

Diodes consist of p-type and n-type semiconductors and can be silicon and germanium. The A-anode is an extract connected with a p-type semiconductor and the K-cathode is an extract connected with an n-type semiconductor. Semiconductor diodes are elements that let current pass only when they are directly polarized and polarized by external voltage.

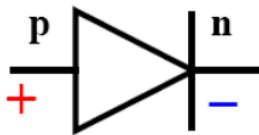

Fig. 3. Permeable polarized diodes

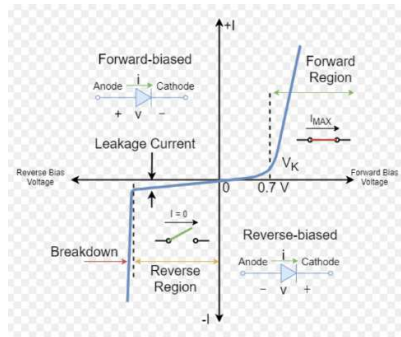

Fig. 4. Current-voltage characteristic of the diode

The current-voltage characteristic of the diode represents the ratio of voltage to current. The diode becomes conductive when the connected voltage reaches the value of U_T . This voltage is called the threshold or knee voltage. For silicon diodes it is about 0.6 V – 0.7 V, and for germanium diodes it is 0.2 V – 0.3 V. [1]

$$\eta = \frac{P_{el}}{P_{sol}} = \frac{U \cdot I}{E \cdot A} \text{ - the degree of utilization of photovoltaic cells} \quad (1.3)$$

P_{el} - Output electrical power,

P_{sol} - Radiation power,

U - Effective value of output voltage,

I - Effective value of output current,

E - Specific radiation power (e.g. in W/m^2),

A - Surface.

The cost-effectiveness of a photovoltaic solar cell is defined as the ratio of the electrical power given by a solar cell to the power of solar radiation. The utilization of the photovoltaic cell is not large, it ranges from a few percent to about 40 %. The remaining energy is converted into heat and thus heats the cell. Heating the cell reduces its efficiency.

2. ELEMENTS OF THE SOLAR SYSTEM

The method of interconnection of modules is in line, parallel, and combined. A photovoltaic panel is created by binding a large number of modules. By tying the module to the row, the voltage value is increased, while the binding of the module in parallel achieves an increase in current. In order to achieve the desired value of voltage and current on the panel, it is necessary to achieve an appropriate coupling of serial and parallel connections of modules.

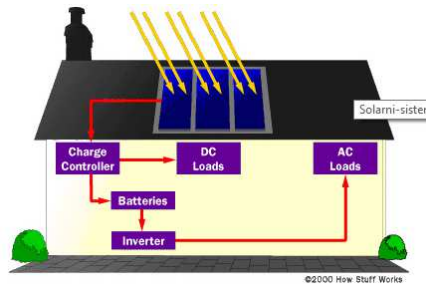

Fig. 5. Components of the solar system

A regular-parallel connection is achieved in two ways. One way-first connects the modules in parallel and then they are connected in series, and the second way-first connects the modules in series and then connects in parallel. Another method of bonding is more efficient because if one row is turned off, the panel can continue to operate with the same voltage but less current.

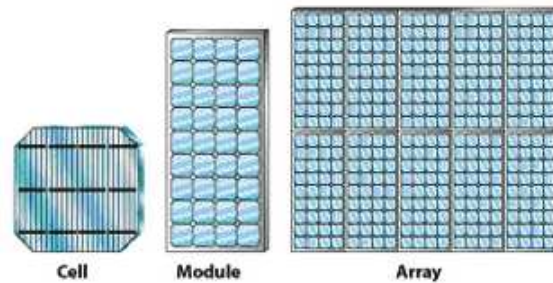

Fig. 6. Photovoltaic cell, module, and panel

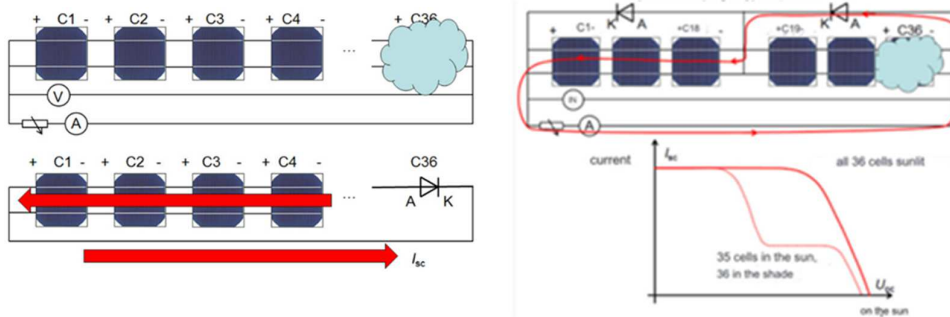

Fig. 7. Scheme of solar modular system

In the case of binding several cells in series and downtime in the operation of one of the cells, the current will not be able to flow and the panel will not produce electricity. In this case, bypass placement is the solution. This implies the installation of a bypass diode through which the current will flow, and the photovoltaic panel will remain operational when a cell is damaged. Under shading conditions, a relatively large dissipation power is generated on the cell itself, which creates warm spots and degrades the cell itself. An effective way to overcome the described problems is to set diodes to bridge if the cell is shaded (bypass diodes). The figure shows the principle of functioning of the bypass diode on the example of one of the cells that is separated from the module.

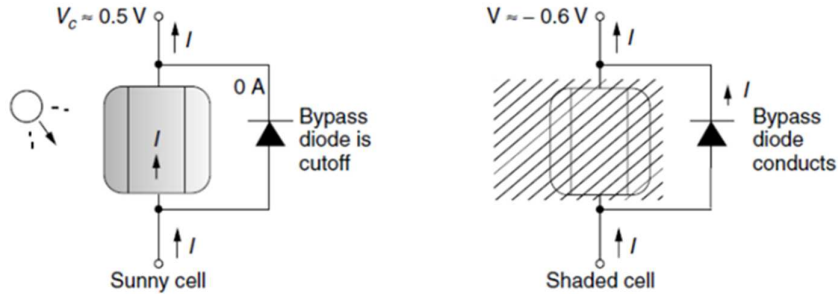

Fig. 8. The principle of functioning of a bypass diode

The bypass diode is placed parallel to each of the serial bound cells. Since the voltage on the solar cell, under normal operating conditions (e.g. at the maximum power point), is about 0.5 V, and the conduction threshold of the directly polarized diode is 0.6 V, the diode will normally be directly polarized but the voltage will be below the conduction threshold (figure left) and the diode will have no role. [10]

When one of the cells is shaded (figure right), a voltage drop is created on the resistance and as soon as the voltage reaches the threshold of conducting the diode it will represent a small resistance and the current will flow through the bypass diode. In this way, the current generated by the other diodes in the series is given a new efficient channel for bridging the shaded diode. The role of the bypass diode is, bridging the module that is overshadowed or in case of failure, which is automatically bridged and electrically isolated from the system.

The photovoltaic cell can be represented by the replacement scheme shown in Figure 9. It consists of a single diode and an ideal current source. The value of PV cell current is:

$$V_d \approx V \Rightarrow I = I_{sc} - I_d = I_{sc} - I_0(e^{\frac{qV}{kT}} - 1) \quad (2.1)$$

I_{sc} -short circuit current

V_d, I_d -voltage, current of diode

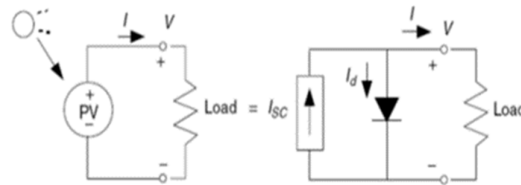

Fig. 9. Photovoltaic cell equivalent scheme

In the case when a photovoltaic cell is illuminated and unlit, I_{sc} is the short circuit current, and the V_{ok} is the open circuit voltage [5], calculated from the expression:

$$0 = I_{sc} - I_0 * \left(e^{\frac{qV}{kT}} - 1 \right) \tag{2.2}$$

$$V_{ok} = \frac{kT}{q} \ln \left(\frac{I_{sc}}{I_0} + 1 \right) \tag{2.3}$$

In case shading occurs, it is necessary to use a complex replacement scheme, by adding the R_p resistor parallel to the diode circuit in an equivalent replacement scheme (Fig.10).

The value of the current in the circuit from Figure 10. is calculated from the expression:

$$I = I_{sc} - I_0 * \left(e^{\frac{qV}{kT}} - 1 \right) - \frac{V}{R_p} \quad V_d \approx V \tag{2.4}$$

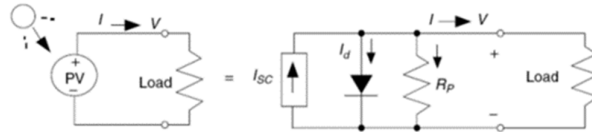

Fig.10. Equivalent photovoltaic cell scheme with parallel resistance

Considering to the expression 2.4, adding parallel resistance to the diode circuit has achieved reducing the current of the photovoltaic cell, what can be concluded by Figure 11.

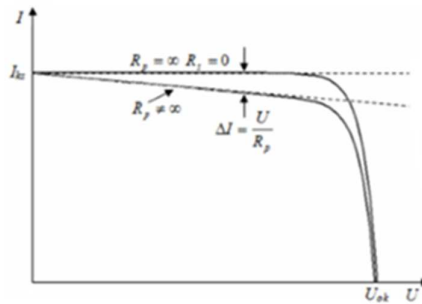

Fig. 11. Effect of parallel resistance to the I-V characteristic of a PV cells

By adding the serial resistor R_s in an equivalent scheme (Fig. 12) the value of the voltage and current is:

$$V_d = V + R_s * I \Rightarrow V = V_d - R_s * I, \quad I = I_{sc} - I_0 * \left(e^{\frac{qV}{kT}} - 1 \right) \tag{2.5}$$

Analyzing this expression, it is concluded that there is a decrease in the voltage of the PV cell. (Fig. 13.)

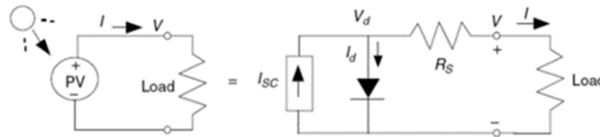

Fig. 12. Equivalent PV cell scheme with serial resistance

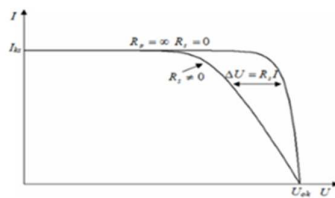

Fig. 13. Effect of serial resistance to the I-V characteristic of PV cells

By combining parallel and series resistance, the most commonly used replacement scheme is shown on the Figure 14, and the effect of the parallel and serial resistor on the I-V characteristic of the photovoltaic cell is shown on the Figure 15.

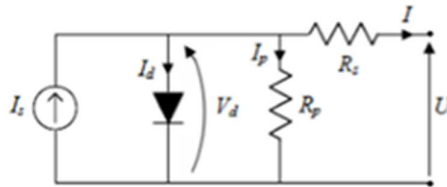

Fig. 14. The most commonly used PV cell replacement scheme

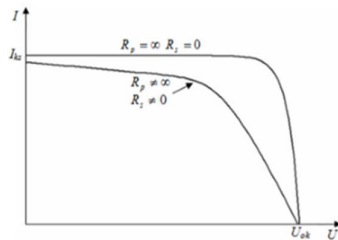

Fig. 15. Effect of parallel and series resistor on I-V characteristic

The current of a photovoltaic cell with a parallel and serial resistor is:

$$I_d = I_s - I_0 * \left(e^{\frac{qVd}{kT}} - 1 \right) - \frac{U + R_s I}{R_p} \quad (2.6)$$

The following figure will show the ways of tying the module into the panel: serial, parallel and by combining. At the same time are described the effects of the method of linking the module on the output values of voltage and current on the panel.

1. By parallel linking of the modules, current of the photovoltaic panel increase and voltage remains the same.

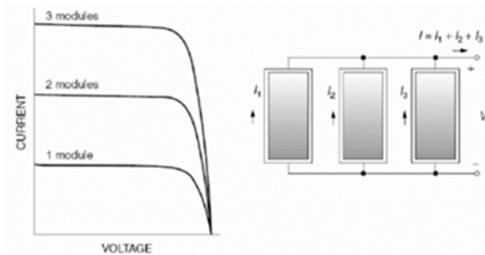

Fig. 16. Parallel connection of modules and I-V characteristics of panels

2. By serial linking of the modules, voltage of the photovoltaic panel increase and current remains the same.

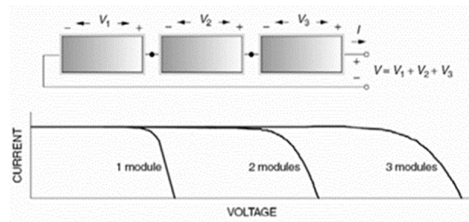

Figure 17. Serial connection of modules and I-V characteristics of panels

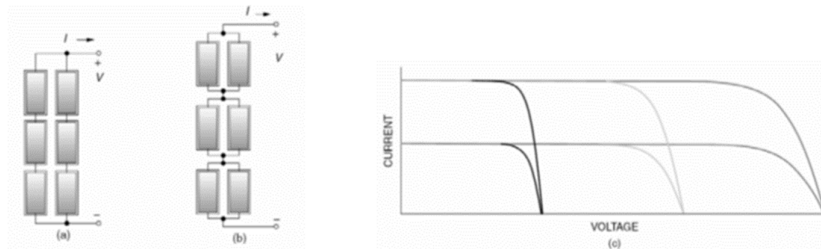

Fig.18. Ways of connecting modules in panel and I-V characteristics of panels

CHARGE CONTROLLER

The voltage regulator is an integral element of the solar-to-electricity conversion system. The role of voltage regulators is to regulate voltage produced from renewable energy sources and proper battery maintenance, i.e. regulation of input voltage and current from solar panels and battery protection. The charging voltage is automatically adjusted depending on the type, the state of charge and the temperature of the battery.

It protects the battery from full discharge and overcharging, and ensures maximum battery life, maintaining performance and efficiency, also integrates the appearance of a short circuit. It prevents the battery from draining through photovoltaic modules during the night when it does not provide voltage. It reduces the maintenance of equipment. Voltage regulators stop charging the battery when the set high voltage level is exceeded. When the voltage regulator manages to keep the voltage below that level, charging continues. This is a continuous occurrence and is known as "battery floating" or "keeping the battery from overcharging." [9]

Two sophisticated voltage regulator technologies can be singled out:

1. PWM-pulse width modulation
2. MPPT- maximum power point tracking

Both types of regulators can adjust charging rates depending on the battery level, allowing the battery to be charged closer to the maximum voltage capacity. The voltage regulator operates according to some predetermined criteria, according to the UI, W or WU characteristic.

Management consists of 3 parts:

1. impact charging of the battery at the maximum current value from the PV module;
2. final battery charging with constant reduction of current value and control of voltage rise, to full charge state.
3. maintaining the state of charge when the voltage is reduced at rest, without consumption, by periodically replenishing the batteries with short current pulses.

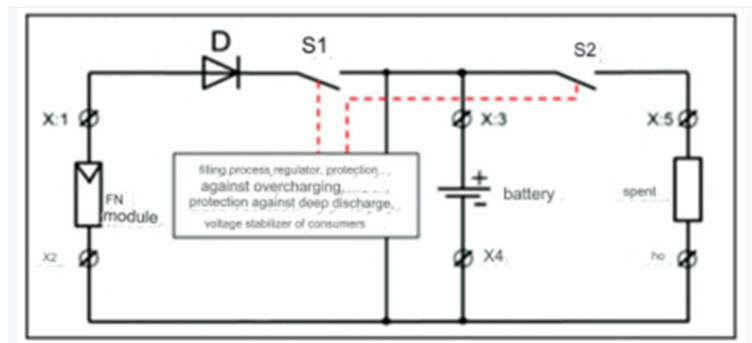

Fig. 19. Charge Controller Scheme

BATTERY

Batteries are elements for energy storage. They are characterized by relatively small dimensions, lack of moving parts (except for flow-through batteries) and direct storage of electricity, through reversible electrochemical reactions. The basic constituents of electrochemical cells are a negatively charged electrode-anode, a positively charged electrode-cathode, and an electrolyte that allows the exchange of ions between electrodes, within a single cell. [7]

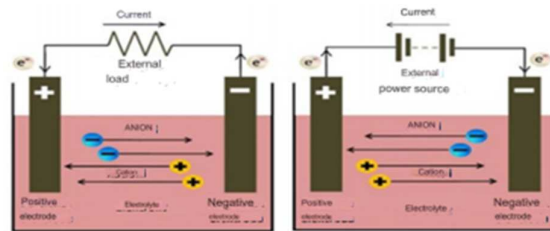

Fig. 20. Electrochemical cell scheme in the case of: a) discharge and b) filling

In the process of discharging the battery, oxidation of the negative electrode occurs, while the positive electrode reduces. In the case of charging, the opposite reaction occurs. Oxidation is a chemical reaction in which electrons are released and then atoms become positively charged ions (anions). The opposite reaction to oxidation is reduction, in which electrons are received and then atoms become negatively charged ions (cations). [7]

Redox-reaction is the common term for oxidation and reduction together. The ratio of the current amount of charge in the battery – Q_{bat} and the maximum charge – Q_{max} represents the state of charge of the battery. It is a dimensionless coefficient and is calculated:

$$SoC = \frac{Q_{bat}}{Q_{max}} \quad (2.7)$$

An important parameter for the battery is the depth of discharge:

$$DoD = 1 - SoC \quad (2.8)$$

INVERTER

A solar inverter is an electrical circuit, which converts the DC voltage of solar modules into alternating voltage, corresponding phases and frequencies. The output voltage is synchronized with the voltage of the network. Inverters can be voltage and current, depending on the nature of the input component. They can be single-phase and three-phase, depending on the number of phase connections at the outlet. [9]

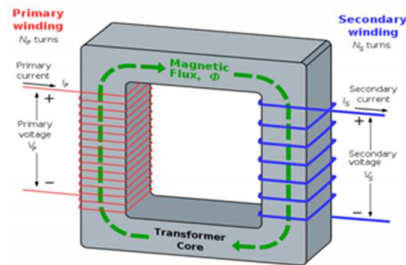

Fig. 21. The process of electromagnetic field produced

The one-way voltage source is connected to the centre of the transformer's primary via a conduit. The switch achieves switching from one position to another, so the current flows to the source of one-way voltage from two directions, through one and then through the other end of the primary. Due to changes in the direction of current in the primary, alternating current is formed in the secondary. Inverter types can be grouped:

- Inverters for feed-in systems (ON GRID)
- Inverters for standalone systems (OFF GRID)
- Inverters for hybrid systems

3. FACTORS AFFECT THE EFFICIENCY OF SOLAR PANELS

Important factors that affect the process of energy production from solar panels are: solar irradiation, ambient temperature and spatial orientation of the photovoltaic panel. [6] The line that connects the centre of the Sun with the centre of the Earth and the projections on to the equator's plane form an angle called the angle of declination and is marked by δ . The value of this angle is between the values $\pm 23.45^\circ$ [2]. The expression by which the angle of declination of any day of the year can be determined is:

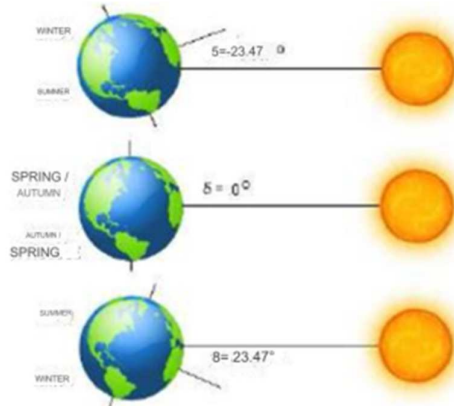

Fig. 22. Position of the Earth and the Sun

$$\delta = 23,45 * \sin\left[\frac{360}{365} * (n - 81)\right] \quad (3.1)$$

n - ordinal number of days of the year

The surface of the panels should be normal to the incoming solar radiation, so irradiation on the surface of the photovoltaic panel will be the largest.

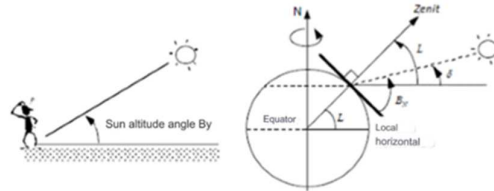

Fig. 23. Explanation of the concept of the altitude angle

The altitude angle of the Sun is the angle between a line that connects an object on Earth and the Sun and projections of that line on a horizontal surface at solar noon. This is the angle at which the observer on earth sees the sun. (Figure 24.)

$$\beta_N = 90^\circ - L + \delta \quad (3.2)$$

Solar noon is the moment when the Sun is located exactly in the south (in the northern hemisphere via $L = 23.45^\circ$), in the north (in the southern hemisphere below $L = -23.45^\circ$) or in the north, south or directly above the observer (between $\pm 23.45^\circ$). The azimuth angle ϕ_S is the angle that is determined in the Northern Hemisphere relative to the south and is by convention adopted to be positive southeast and negative southwest. In relation to the north, this angle is measured in the southern hemisphere.

The latitude of the observed place, the day of the year and the time of day are factors that directly influence the determination of the azimuth and altitude angles: [2]

$$\sin \beta = \cos L * \cos \delta * \cos H + \sin L * \sin \delta \quad (3.3)$$

$$\sin \phi_s = \frac{\cos \delta * \sin H}{\cos \beta} \quad (3.4)$$

Where are: L -latitude, δ -solar declination angle, H -hour angle.

H-hour angle: The angle by which the earth must rotate before the Sun will be over the local meridian and Earth is rotating 15 degrees in every hour, so hour angle can be calculates as:

$$H = \frac{15^\circ}{\text{hour}} * (\text{hours before noon})$$

Solar noon time can be assumed as 12 noon, but actual value is a little more or less.

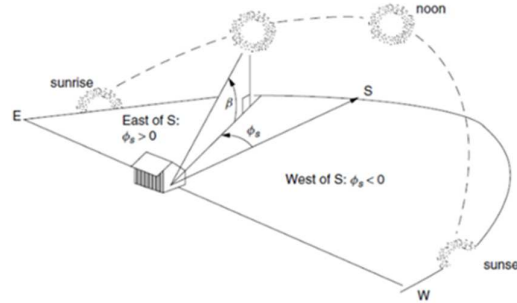

Fig. 24. The position of the Sun in the sky, the altitude angle of the β and the azimuth angle of the Sun ϕ_s

The coefficient of efficiency shows which part of the sun's energy is converted into electricity:

$$\eta = \frac{V_m \cdot I_m}{1000 \left[\frac{W}{m^2} \right] \cdot A [m^2]} \quad V_m, I_m \text{ at maximum power, } A - \text{panel area} \quad (3.5)$$

The efficiency depends on the spectrum and intensity of the incident sunlight and the temperature of the solar cell. Therefore, conditions under which efficiency is measured (STC: Cell temperature: 25°C, Irradiance: 1000 W/m², Air mass: 1.5) must be carefully controlled in order to compare the performance of one device to another. In actual installations the cell temperature rises leading to an efficiency reduction.

Standard Test Conditions (STC) are the industry standard conditions under which all solar PV panels are tested to determine their rated power and other characteristics. Since all manufacturers follow this same standard, it gives a fair basis to compare them against each other. [11]

The temperature of the cell in the PV module is determined:

$$T_{PV} = T_{amb} + \left(\frac{NOCT - 20^\circ}{0,8} \right) * I_C \quad (3.6)$$

T_{amb} ambient temperature

I_C solar irradiation

NOCT-Nominal Operating Cell Temperature (Cell temperature: 20°C, Irradiance: 800 W/m²,

Air speed: 1m/s)

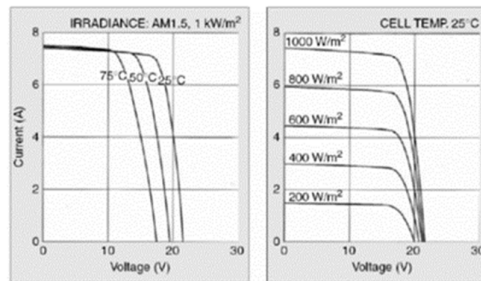

Fig. 25: Influence of temperature and irradiation on I-U characteristic of modules

4. SOLAR POWER PLANT "ČEVO SOLAR"

The first photovoltaic power plant for electricity generation in Montenegro is SE "ČEVO SOLAR". The main elements of the power plant system consist of the following elements: - photovoltaic panels (PV panel) and their supports: - inverters, - low-voltage cabinets (0.8kV plant), - power transformers, - 35kV plants, - connection lines to the distribution network.



Fig. 26. Solar power plant "Solar Čevo"

The installed power of the SPP is 4,421,040 W_p, which is obtained from 8112 photovoltaic panels, each with a power of 545W_p ($P_{\text{panelplant}} = 26 \text{ inv} \times 6 \times 2 \times 26 \text{ panels} \times 545 \text{ W}_p = 4,421,040 \text{ W}_p$). Model of photovoltaic panels is: SRP-545-BMA-BG manufactured by JIANGSU SERAPHIM SS CO., LTD and they are connected in sequence in strings so that 26 panels make up one string. Solar panels are installed on a steel structure on the ground, and they are designed to provide optimal electricity generation throughout the year.

The structure on which photovoltaic panels are mounted or fixed, is made of hot-dip galvanized steel and is placed under a slope of 25° in relation to the south-oriented ground. At the ends of a series of solar panels on the steel structure, are positioned 26 inverters with a power of 125 kW, through them is carried out the conversion of electricity to the voltage level of 0,8kV AC. The total power of the Solar Power Plant is achieved of 3,250,000 We (total installed power of the solar power plant: $P_{\text{plant}} = 26 \text{ inv} \times 125,000 \text{ W} = 3,250,000 \text{ W}$).

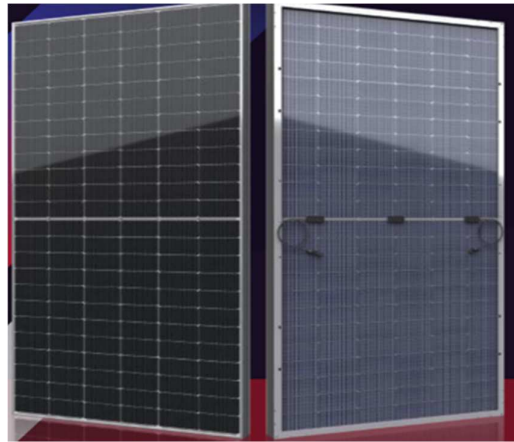

Fig. 27. Model of PV panel type SRP-545-BMA-BG

The type of built-in inverters is: SG125HX, manufactured by SUNGROW and have IP66 protection, so its exposure to outdoor atmospheric conditions is allowed. This inverter has protection against island operation, i.e. this inverter turns off in case of loss of mains voltage- it is not possible to produce electricity from the solar power plant distributed into the network in case the mains voltage is not present. There are 12 strings connected to one inverter- 2 strings per MPPT. The interconnection of the panels is achieved by factory-derived 4mm^2 cross-sectional conductors and MC4 connectors. The inverter is connected to the end panels in the string via a conductor H1Z2Z2K $2 \times 1 \times 6 \text{ mm}^2$. From each inverter to the cabinet of 0.8kV voltage in the substation are laid cables (26 cables) consisting of four cables type NAPP $1 \times 120\text{mm}^2$, 0.6/1kV.



Fig. 28. Model of inverter type SG125HX, SUNGROW

The total potential production at the year level is 6 064 522 kWh.

An integral part of the SPP is the facility of the substation SS 35/0,8kV in which there is: medium voltage plant 35kV, low voltage plant 0.8kV, two transformers with a power of 35/0.8kV 2000kVA and one transformer with a power of 35/0.4kV 50kVA for its own consumption. The connection of the Power Plant to the distribution system is carried out at the voltage level of 35kV at the 35kV transmission line "Čevo-Cetinje", which passes over the plots on which the Solar Power Plant has been built. Connection is carried out via 35kV cable line that is connect the new TS 35/0.8kV with the existing 35kV DV "Čevo-Cetinje", according to the "input-output" system. The power plant will work in "On grid" mode- the generated electricity will be distributed only in moments of the presence of mains voltage. In the case of a failure of the mains voltage, the power plant will be disconnected from the mains. Within the 35kV plant there is a load cell with built-in measuring current and voltage transformers from which the conductors are laid to the measuring board (placed on the wall of the substation), and in which there is an indirect calculation meter. The meter has the possibility of measuring the flow of energy in both directions, namely: registering the consumed energy by the consumer in the power plant on the one side and on the other side the possibility of registering the transmitted energy by the power plant to the distribution network. The system for remote collection of measurement data and other auxiliary devices for remote collection of measurement data (communication equipment) is carried out through devices located at the measuring point. The generated electricity of the power plant before handing over to consumers either in the solar power plant or in the grid, is registered using control internal semi-indirect meters located in the cabinet of a low-voltage block of 0.8 kV (for each block one). The own consumption of the solar power plant is measured using a control internal semi-indirect meter located within the cabinet of a low-voltage block of 0.4 kV.

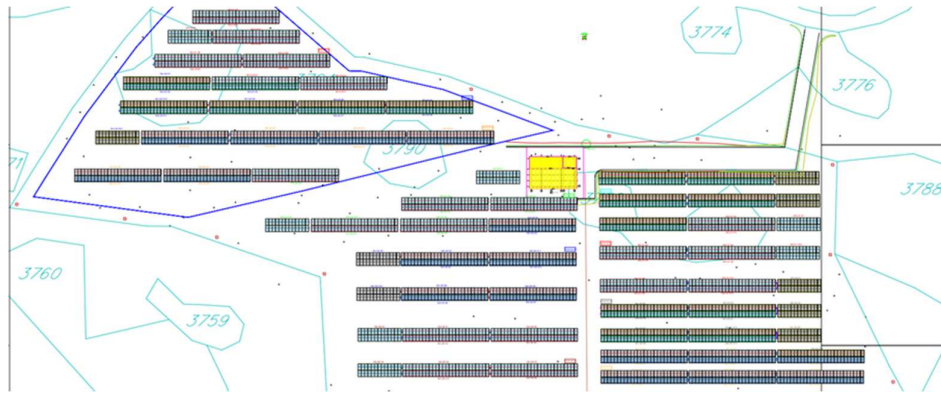

Fig. 29. Position of panels on the ground from EE project

Protections of solar power plants-elements of switchgear and connection line were realized, from possible accidents and damage due to failures and disruptions in the distribution system and internal failures, within the distribution cabinets of AC voltage and within the inverter itself. In all inverters are installed factory surge arresters as protection from the DC side of the inverter as well as all protections defined by the standard EN 50549-2. Within the distribution cabinets of low voltage 0.8kV, three-pole circuit breakers, surge arresters and cable protection are installed through which the inverters are connected to the low-voltage block. Low-voltage circuit breakers with thermal and magnetic protection are also installed, which work to disconnect the circuit breaker in the event that the nominal values are exceeded and are provided as protection of cables through which the inverters are connected to the low-voltage block. Surge protection in these cabinets is achieved by installing surge arresters type 1 +2 on the main busbars of these cabinets. The main protections of the power plant are located in a medium voltage 35kV block in the form of microprocessor protective units mounted in all medium voltage cells. The protective and control devices are P3 series, manufactured by "Schneider Electric" and in all cells, except the measuring cell, the type of device is provided: P3F30 (P3F30-CGGIAAAENA-BBAAA).

The principle of operation of the solar power plant works independently under normal operating conditions, it is switched on and off the grid without the mediation of a professional face. Switching on and off power plants are defined by operating voltage ranges generated by sunlight. The possibility of monitoring the power produced by the power plant is provided through the display on the inverter, via mobile or computer application with the pre-connection of the inverter to the Internet (WLAN or Ethernet).

5. CONCLUSION

This work describes the concept of photovoltaic effect as a revolutionary discovery in the development of productive electricity from solar energy. As an integral part of the solar power plant, the principle of operation of all elements is individually explained, mathematical

models are presented, the possibilities of connecting individual elements are considered in order to find the most efficient model and economical. The schemes shown are substantiated by diagrams.

The first solar power plant built in Montenegro is presented by photos from the field and description of the principle of operation. The advantages of the development and implementation of solar power generation are enormous, solar energy is free, unlimited and clean, the system is easy to set up, maintained simply, is a financially profitable investment.

REFERENCES

- [1] Ratko Opačić, Elektronika I, Zavod za udžbenike i nastavna sredstva, Beograd, 2002
- [2] M.L.Roderick, Methods for calculating solar position and day length including computer programs and subroutines; Resource Management Technical Reports, Department of Agriculture and Food, Western Australia, Report 137, 1993
- [3] Iva M. Babić, Modelovanje uticaja vremenskog profila solarnog zračenja na efekte rada fotonaponskih sistema u elektroenergetskom sistemu -doktorska disertacija, Beograd, 2016
- [4] Mboumboue Edouard, Donatien Njomo Mathematical modeling and digital simulation of PV solar panel using matlab software, University of Yaoundé I, Cameroon, 2013
- [5] Mukund R. Patel, Wind and solar power systems; U.S. Merchant Marine Academy Kings Point, New York, U.S.A. 2006
- [6] Anita Gegić-Petrović, Branko Savić, Analiza uticaja različitih faktora na efikasnost rada fotonaponskih panela, Visoka tehnička škola strukovnih studija Novi Sad, Republika Srbija, 2014
- [7] *AltE Store*: <https://www.altestore.com>, [Accessed: 25.09.2023.]
- [8] *Greenmatch*: www.greenmatch.co.uk, [Accessed: 23.08.2023.]
- [9] *Wikipedija*: <https://en.wikipedia.org>, [Accessed: 06.09.2023.]
- [10] Željko Đurišić, Obnovljivi izvori energije - projektovanje fotonaponskih sistema; Univerzitet u Beogradu, Elektrotehnički fakultet, Energetski odsek.
- [11] *Solar design guide*: <https://solardesignguide.com/stc-and-noct-solar-panel-test-conditions-explained>, [Accessed: 22.11.2023.]